

TSF Series

TraySealers Packaging Machines

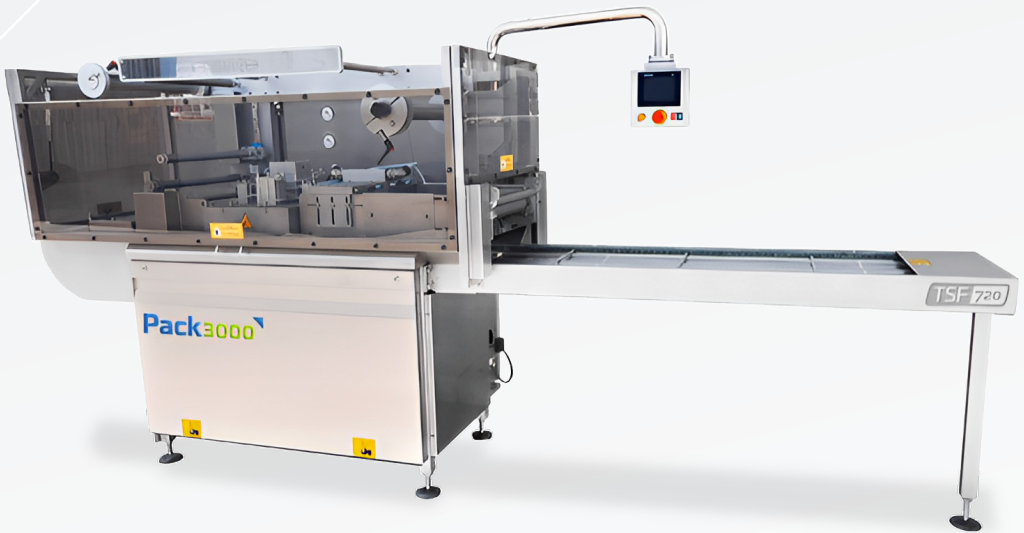

Technical characteristics

- AISI 304 stainless steel structure.
- 5.7" color touch screen.
- Vacuum sensor for millibars and time or both at the same time.
- Gas injection per millibar and time.
- Film drag by two synchronized motors.
- Adaptation of molds to the customer's choice.
- Power: 12-20 KW (according to pumps)
- Replaceable ring to adapt trays from any manufacturer.
- Film advance modes: by length - by printed macula.
- Trays drags by stainless steel rods dragged by chains.



FlatSkin



Pack3000

your
PRODUCT
our PASSION



FlatSkin

TSF 720

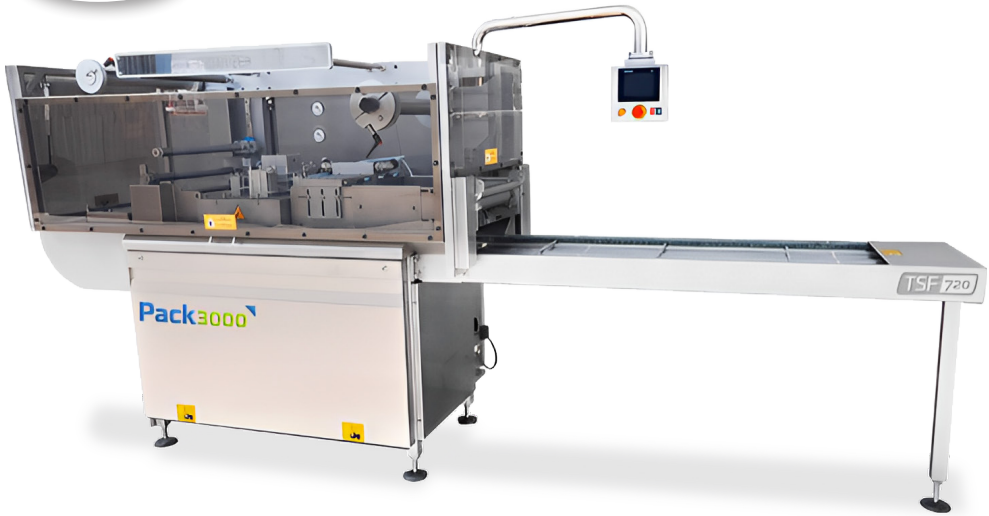

General characteristics

- Scrap collector.
- Possible packaging systems (According to molds purchased).
Sealed
- **Central access** for maintenance and greasing point.
- Different **levels** of Access.
- Defined number of **production programs**.
- **Maintenance programs** with machine draws and parts numbers.
- **Preventative** maintenance sign.

Capacity

- Two 1/2 GN trays.
- Three 1/4 GN trays.
- Four 1/8 GN trays.

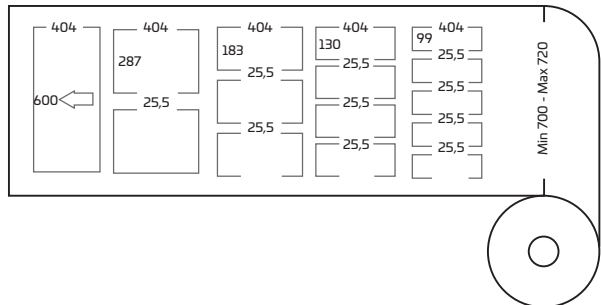

Pack3000



We cover North America coast to coast with first class service and parts. Please contact us for more details and information:

sales@pack3000.com
www.pack3000.com